

Project _____ Type _____ Model # _____

Remarks

Description: Firehorse Emergency Ballast for use with or without AC ballast designed to add emergency lighting when main AC power is interrupted for minimum of 90 minutes at reduced illumination. The emergency ballast is not intended for general purpose lighting applications. Complies with minimum light output for emergency lighting equipment as per UL 924, supplement "SH". Consult with factory when using EM Ballast with low mercury lamps (TCP).

This Ballast Will Operate Following Lamps.

- 1 X F21T5, F28T5, F24T5HO, F35T5, F39T5HO, F54T5HO, F25T8, F32T8 (28W), F32T8 (32W), F40T8, F44T8HO, F51T8, F59T8, F86T8HO, F25T12, F30T12, F40T12 (34W), F40T12 (40W), F75T12, F85T12, F96T12HO (95W), F96T12HO (110W), FT36W, FT40W, FT50W, FT55W, CFTR 57W, CRT5 22W, CRT5 40W, CRT5 55W, CRT9 20W, CRT9 32W, CRT9 40W, 2D/28/38/55W, FB32T8, FB34T12, FB40T12
- 2 X F21T5, F25T8, F28T8 (28W), F32T8 (32W), F40T8, F25T12, F30T12, F40T12 (34W), F40T12 (40W), FT36W, CRT5 22W, CRT5 40W, CRT9 20W, CRT9 32W, 2D/28W, FB32T8, FB34T12

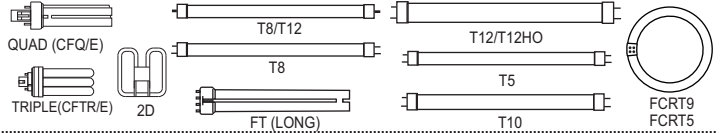

ELECTRICAL DATA

BALLAST TYPE / OUTPUT TYPE	EMERGENCY
INPUT VOLTAGE	120V OR 277V ± 10%, 60 Hz
AC INPUT POWER RATING	2.9W @ 120V / 3.1W @ 277V
AC INPUT CURRENT RATING	270mA @ 120V / 250mA @ 277V
BATTERY TYPE	MAINTENANCE FREE - HIGH TEMPERATURE RECHARGEABLE SEALED NI-CAD
BATTERY VOLTAGE	3.6Vdc
BATTERY CHARGING CURRENT	280mA
BATTERY RATING	14.4Wh
BATTERY CAPACITY	4.0Ah
TEMPERATURE RATING (AMBIENT)	0°C TO 50°C (32°F TO 122°F)
MAX INITIAL LIGHT OUTPUT	700 LUMENS
MINIMUM ILLUMINATION TIME	90 MINUTES
RECHARGE TIME	24 HOURS
TEST SWITCH TYPE	ILLUMINATED TEST SWITCH PILOT LIGHT
CHARGING INDICATOR LIGHT TYPE	LED
CASE PROFILE	9.4"L X 2.4"W X 1.5"H X 8.9" MOUNTING CENTER
CASE WEIGHT	2.8 lbs.
CASE TYPE	VANDAL RESISTANT - SEALED
CASE CONSTRUCTION	PAINTED STEEL SILVER FINISH
WIRE CONNECTION	STANDARD WIRE LEADS
APPROVAL CLASS	UL - LISTED FOR DAMP LOCATION - FACTORY OR FIELD INSTALLATION
CODE COMPLIANCE	MEETS OR EXCEEDS UL924 - N.E.C AND NFPA 101 LIFE SAFETY CODE EMERGENCY OPERATING REQUIREMENT
AC COMPATIBILITY	ELECTRONIC FLUORESCENT - STANDARD AND DIMMING
LAMP COMPATIBILITY	4-PIN FLUORESCENT WITHOUT INTEGRAL STARTER
LUMINAIRE COMPATIBILITY	INDOOR SWITCHED AND UN-SWITCHED TYPE
END OF LIFE (EOL) COMPATIBILITY	YES (TIME DELAY CIRCUIT)
WARRANTY	3 YEARS

MECHANICAL DATA

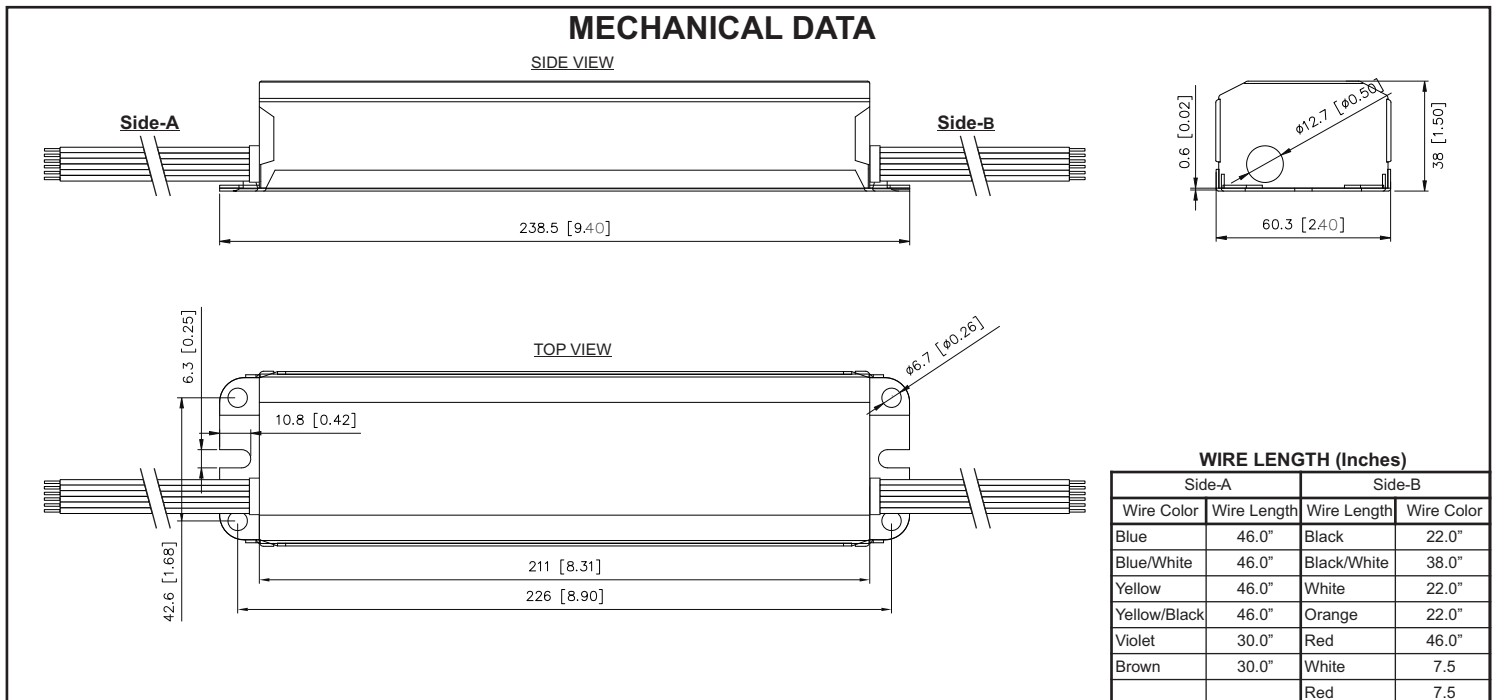

APPLICATION

The FireHorse emergency ballast can be used to add emergency lighting with or without an AC ballast and with most fluorescent luminaires without affecting normal luminaire operation. The emergency ballast is designed for factory or field installation and can be mounted on top, inside, or remote from the luminaire.

If used in an emergency-only luminaire, no AC ballast is required. The FireHorse emergency ballast is not suitable for use in air handling heated air outlets, outdoor, wet, or hazardous locations. The emergency ballast should not be installed near gas or electric heaters. The FireHorse emergency ballast is rated for Indoor Dry/Damp locations, including luminaires rated for UL wet locations .



Hardware kit and instruction sheets are included with EM Ballast.

OPERATION

The FireHorse emergency ballast is designed to immediately switch to the emergency mode when the primary AC power is interrupted, illuminating one or two lamps at a reduced lumen output for a minimum of 90 minutes. Upon restoration of primary AC power; the FireHorse emergency ballast immediately returns to a battery charging mode. The LED indicator light source when illuminated indicates battery is in charge mode when AC power is applied. It is recommended and by code required to test the emergency ballast every 30 days to ensure that the ballast is functioning as evidenced by reduced illumination of one or two lamps when pushing the test switch. It is also recommended a 90 minute discharge test is performed one time every 12 months. Battery requires 24 hours to fully re-charge.

INSTALLATION

The FireHorse emergency ballast may be used with either a switched or un-switched luminaire. If a switched luminaire is used, an un-switched hot lead must be connected to the emergency ballast to ensure the ballast remains in an uninterrupted charge condition while primary AC power source is active. Reference Installation Instructions for appropriate wiring or contact Fulham Customer Service.

The FireHorse emergency ballast must be fed from the same branch circuit as the AC ballast. Installation is not recommended with luminaires where the ambient temperature may fall below 0° C for extended periods as this may affect the operation of the emergency ballast.

REMOTE MOUNTING

The FireHorse emergency ballast may be remote-installed up to half the distance the AC ballast manufacturer recommends for remote mounting the AC ballast from the lamp, or up to 50 feet, whichever is less distance. The remote test switch plate may be mounted within 50 feet of the luminaire and is subject to NEC and applicable local electrical code.

UL and CODE COMPLIANCE

The FireHorse emergency ballast has been tested by Underwriters Laboratories in accordance with the standards contained in UL924, "Emergency Lighting and Power Equipment", and is UL approved for factory or field installations. Emergency illumination time meets or exceeds the National Electrical Code (NEC), Life Safety Code (NFPA-LSC) and UL 90 minute requirements.

BATTERY

The FireHorse emergency ballast contains a uniquely constructed, high-temperature rechargeable nickel cadmium battery. The battery is sealed within the ballast housing and is not replaceable. The battery must be recycled or disposed of properly and in compliance with federal, state and local regulations.

EMERGENCY ILLUMINATION

Illumination output varies with number of lamps, either 1 or 2 lamps, and lamp wattage requirement. The FireHorse model FH4-DUAL-700L is designed to produce 300-700 initial emergency lumen output; if model works with 2 lamps the total initial lumen is distributed between the 2 illuminated lamps. Refer to Compatible Lamp List Lumen Output Chart for average lumen output for selected lamps.

SPECIFICATION

Emergency lighting shall be provided by using a FireHorse emergency ballast with a standard fluorescent luminaire equipped with or without an AC ballast. The emergency ballast shall be capable of operating one or two fluorescent lamps as referenced in Table 1. The emergency ballast shall conform to specifications contained in Electrical Data Table and comply with standards set forth by the current NEC. The emergency ballast shall be UL approved for installation on top, inside, or remote from the luminaire.

NOTE: USE OF LOW MERCURY "GREEN" LAMPS

A growing number of fluorescent lamp manufacturers have reduced the level of mercury content in their products. While this is helpful to the environment, the lower mercury content makes the lamp more difficult to start in emergency mode, particularly in a compact fluorescent cold-start emergency-only application without an AC ballast. Please contact Fulham Customer Service for further assistance if needed.

WARRANTY

Fulham Co., Inc. extends limited warranty only to the original purchaser or to the first user for the period of 3 years from the date of manufacture as indicated by the date code stamped on each product and when properly installed and under normal conditions of use. For additional warranty guide line, please refer to our Complete Product Catalog (www.fulham.com) OR call Customer Service at 1-323-779-2980. Due to a program of continuous improvement, Fulham Co., Inc. reserves the right to make any variation in design or construction to the equipment described.

**COMPATIBLE LAMP LIST
LUMEN OUTPUT CHART**

FH4-DUAL-700L WITHOUT INTEGRAL STARTER	WATTS	INITIAL LUMEN OUTPUT	
		1 LAMP	2-LAMPS
F21T5	21W	575	650
F28T5	28W	675	X
F24T5HO	24W	700	X
F35T5	35W	650	X
F39T5HO	39W	700	X
F54T5HO	54W	700	X
F25T8	25W	625	700
F32T8	28W	630	600
F32T8	32W	600	700
F40T8	40W	650	700
F44T8HO	44W	625	X
F51T8	51W	675	X
F59T8	59W	700	X
F86T8HO	86W	700	X
F25T12	25W	450	500
F30T12	30W	500	550
F40T12	34W	575	600
F40T12	40W	625	650
F75T12	75W	675	X
F85T12	85W	700	X
F96T12HO	95W	700	X
F96T12HO	110W	700	X
CFTR57W	57W	675	X
FT36W	36W	600	700
FT40W	40W	625	X
FT50W	50W	650	X
FT55W	55W	675	X
2D28W	28W	550	600
2D38W	38W	650	X
2D55W	55W	700	X
CRT5	22W	425	550
CRT5	40W	600	700
CRT5	55W	650	X
CRT9	20W	400	500
CRT9	32W	450	550
CRT9	40W	500	X
FB32T8	32W	575	675
FB34T12	34W	550	650
FB40T12	40W	600	X

Full compatible lamp list - lumen ratings may vary with lamp specifications, light loss, lamp and luminaire maintenance and other utilization factors.
NOTE: WIRING DIAGRAMS SHOWN ON SEPARATE SHEET

"X" INDICATES LAMP COMBINATION NOT COMPATIBLE

EMERGENCY BALLAST AND AC BALLAST MUST BE FED FROM THE SAME BRANCH CIRCUIT
 TYPICAL SCHEMATICS ONLY. MAY BE USED WITH OTHER BALLASTS. CONSULT THE FACTORY FOR OTHER WIRING DIAGRAMS.

WIRING DIAGRAMS FOR ONE LAMP EMERGENCY OPERATION

1. One (1) Lamp Instant Start AC Ballast

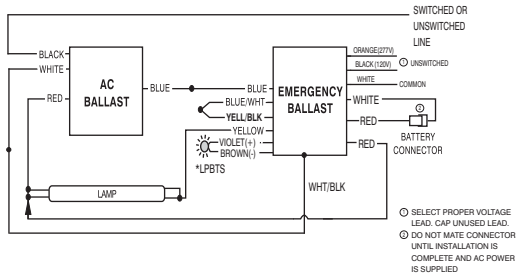

2. Two (2) Lamp Instant Start AC Ballast

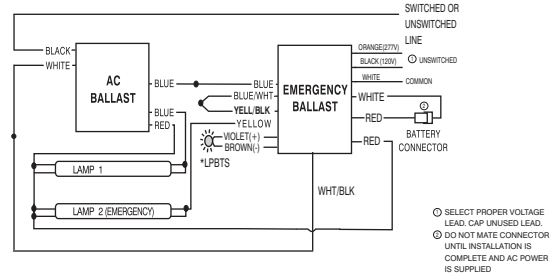

3. Three (3) Lamp Instant Start AC Ballast

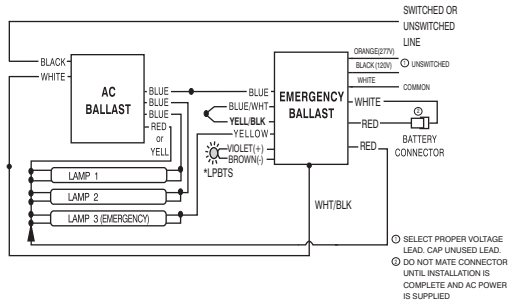

4. Four (4) Lamp Instant Start AC Ballast

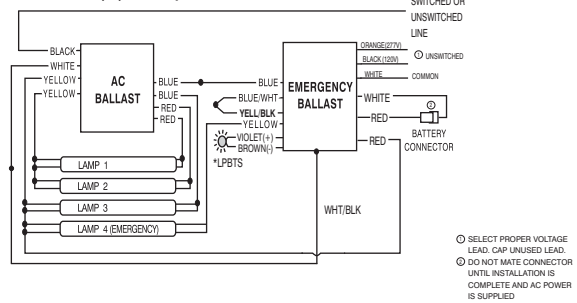

5. One (1) Lamp Rapid Start AC Ballast

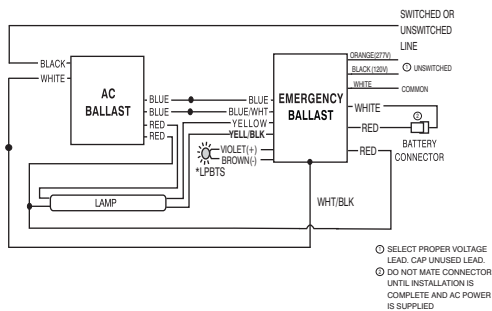

6. Two (2) Lamp Rapid Start AC Ballast

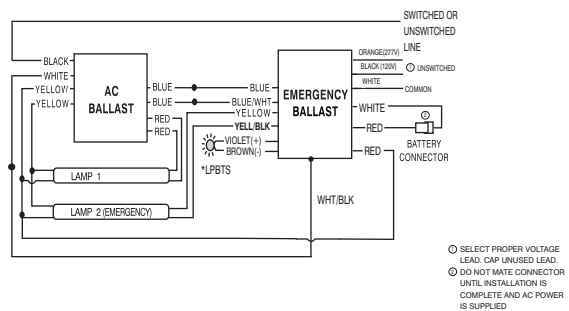

7. Three (3) Lamp Rapid Start AC Ballast

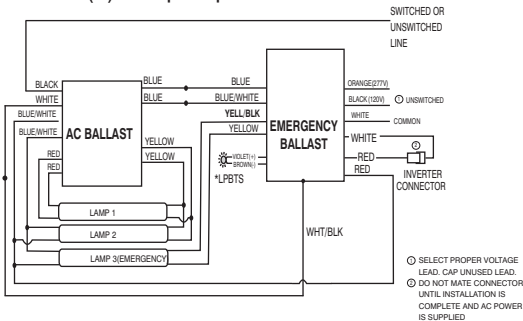

8. Four (4) Lamp Rapid Start AC Ballast

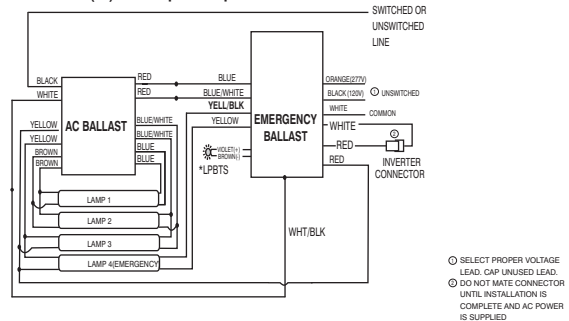

*LIGHTED PUSH BUTTON TEST SWITCH (LPBTS)

USE PROPER CAPS TO TAP UNUSED LEADS

EMERGENCY BALLAST AND AC BALLAST MUST BE FED FROM THE SAME BRANCH CIRCUIT
TYPICAL SCHEMATICS ONLY. MAY BE USED WITH OTHER BALLASTS. CONSULT THE FACTORY FOR OTHER WIRING DIAGRAMS.

WIRING DIAGRAMS FOR TWO LAMP EMERGENCY OPERATION

9. Two (2) Lamp Instant Start AC Ballast

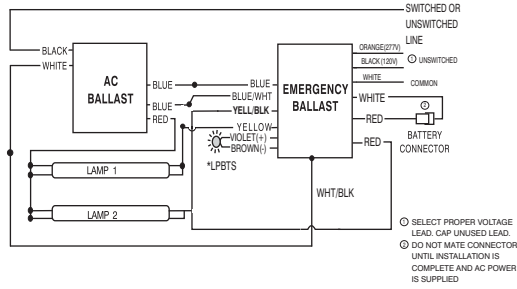

10. Three (3) Lamp Instant Start AC Ballast

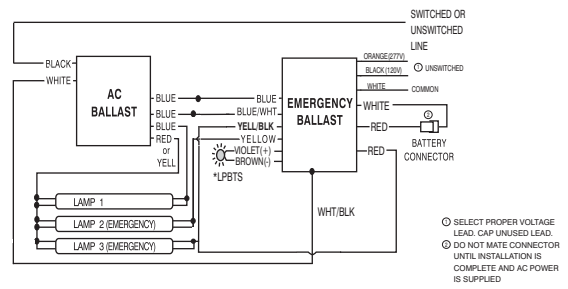

11. Four (4) Lamp Instant Start AC Ballast

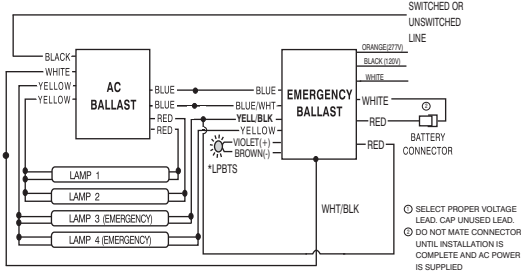

12. Two (2) Lamp Rapid Start AC Ballast

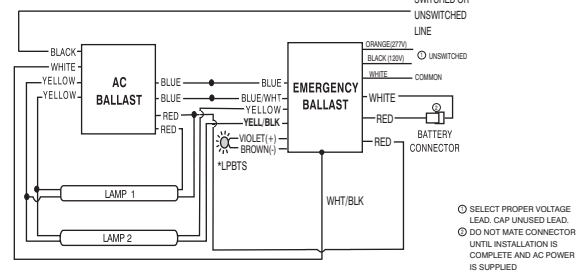

WIRING DIAGRAMS FOR EMERGENCY ONLY OPERATION

13. One (1) Lamp Without AC Ballast

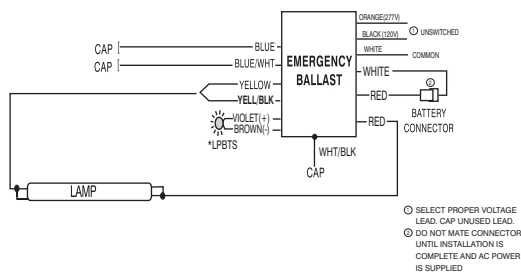

14. Two (2) Lamp Without AC Ballast

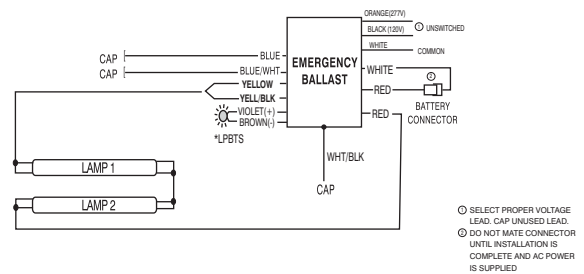

*LIGHTED PUSH BUTTON TEST SWITCH (LPBTS)

USE PROPER CAPS TO TAP UNUSED LEADS